

TECHNICAL DATA SHEET

PRODUCT APPLICATION

The experience and professionalism gained through years of production makes us a reliable partner offering us the market with high quality products and keeping up with the requests.

Our cash drawers can be used for all kind of POS and ECR use cases.

Certification CE 2001/91/CE, CE2014/35/UE,, certification RoSH, TÜV drop test, TÜV vibration test, TÜV mechanical safety test.

KEY FEATURES

- High quality materials, including robust steel, durable abs plastic, and a resilient powder-coated finish suitable for various environments.
- The push spring and high-load-bearing rollers undergo rigorous testing, surpassing 1 million open/closing cycles.
- Removable insert, 4 banknotes metal clip / 8 coins, removable coin case
- Options:
 - Micro switch sensor
 - Stainless steel front panel
 - Lockable cover lid with key for insert
 - Cable output from the bottom
 - Different keylock combinations
 - USB Interface



TECHNICAL DATA SPECIFICATION

Dimension	330W x 335D x 100H mm
Color	Black, White, RAL#
Media slot	1
Material	Steel, ABS plastic
Slide system	Rollers
Insert	4 bill metal clip / 8 coin, removable coin section
Solenoid voltage	12V/24V
DC interface	RJ11, 1.000mm cable length, output from the top
Keylock set	3 position (Open, Electronically open, Close), 2 keys, single combination
Net, Gross weight	5.2 KG, 5.5 KG
Package size	382W x 398D x 155H mm

TECHNICAL DRAWING

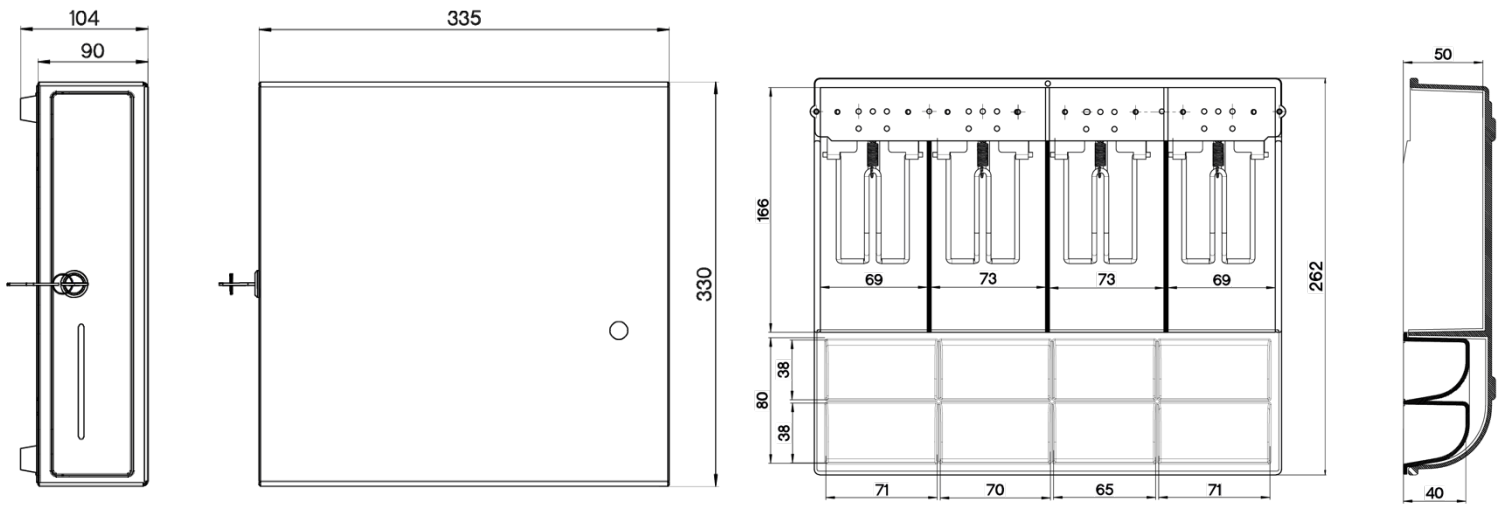

PIN SCHEME

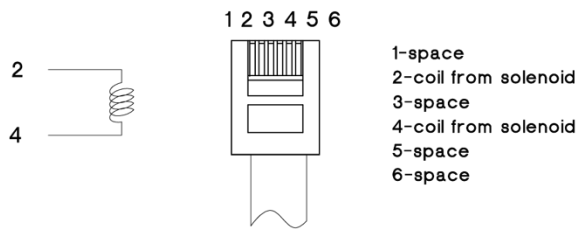
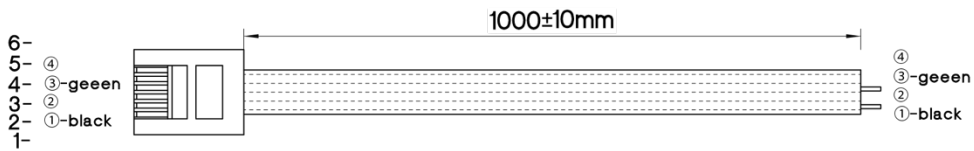

Cash box output interface